

DANIEL DE PAULA

FRANCESCA MININI

VIA MASSIMIANO, 25
20134 MILANO
T +39 02 26924671
INFO@FRANCESSCAMININI.IT
WWW.FRANCESSCAMININI.IT

DANIEL DE PAULA

b. Boston, USA 1987

Lives and work between São Paulo (BR) and Maastricht (NL)

Recent propositions by **Daniel de Paula** seek to activate and exhaust a multitude of agents and relations in a given spatial context. Through an attitude that does not incarcerate itself in the field of art, thus being intersected by concepts from architecture, geography, geology and astronomy, his work amplifies the logics deduced from the very own behavior and history of objects and places. The operations employed by the artist suggest an indivisible bond between the objects presented and the actions that give them existence, presence, and significance. Through strategies such as negotiations with and within city structures, displacement of quotidian objects, appropriation of public infrastructure, and interaction with constitutive agents of the exhibition space and its surrounding landscape, his pieces, installations, and interventions attempt to disarticulate, reconstruct and resignify rigid and conditioned spatial and conceptual systems and configurations.

Artist Statement_

Currently, my investigations intend to reflect upon the production of space as the reproduction of dynamics of power and domination, thus revealing critical concerns regarding the historical, political, social, and economic structures that shape places and relations.

Furthermore, through a practice and posture that is intersected by notions of human geography, my research manifests the interest in understanding the complex social form hidden within materiality, where the dominance of objects over individuals evidences the dominance of individuals over themselves.

Therefore, through the intertwining of conceptual strategies such as, for example, negotiations with and between public and private agencies, and the appropriation, displacement, and recontextualization of objects and images imbued with preexisting contextual narratives, my artistic propositions emphasize the indivisibility between the physicality of the works presented and the circumstances from which they arise, ultimately producing an inseparable field of actions and objects capable of proposing resignifications and ruptures of rigid spatial perceptions and systems.



Gallery exhibitions



*the control of things over subjects is the control
of subjects over themselves*

Opening 14 November 2019
Until January 2020

For the purpose of my first exhibition at Francesca Minini, entitled *the control of things over subjects is the control of subjects over themselves*, as a recurring strategy within my practice, in place of commissioning an external curatorial essay, I've decided to write and provide a short statement as an accompaniment to the presented works, followed by an excerpt derived from an interview I conducted specifically for this occasion with sociologist and professor Saskia Sassen.

Through a posture that attempts to overcome the traditional dichotomy of physicality and action, the exhibition articulates and composes, by means of juxtaposing a series of objects and strategies, a critique towards the production of space as the reproduction of abstract social forms and relations of dominance.

The investigative result being, on its most fundamental level, that, as humans endlessly transform and construct space in order to satisfy their necessities, specifically to exchange commodities within a capitalist society, a system of constraint establishes itself, not simply as class-domination, or the control of people by other people, but by the domination of all subjects by abstract social structures constituted by ourselves.

Under such system of constraint, in which, through the ubiquitousness of labor, and the production of value, we are condemned to transform thoughts into things, materiality is not neutral, on the contrary, it is the embodiment of control and the circulation of power.

Power flows through things, and, in many instances reveals the exchange of roles that takes place between individuals and commodities in modern capitalism, where life becomes objectified and expendable, while materiality is fetishized and invested with substance and the active agency of spiritual entities.

In addition to the space of the gallery, the exhibition is composed by materials such as: video-inspection footages of oil, water, geothermal energy, and gas extraction wells

lunar rock fragment
granulated copper recovered from high-speed communication data cables
rock core samples derived from geotechnical surveys performed for works of urban mobility
dead worker's wristwatch with counterclockwise-functioning
fulgurite (tube-like rock formation caused by lightning discharge into the ground)

Despite the notion of artworks and the artistic field as being autonomous and positively charged, supposedly detached from, and solely representational of the collapsing world, art is a commodity, and plays an equal role in the reproduction of the catastrophic social relations that control us.

Daniel de Paula

As a final note, please find below brief fragments derived from an interview with sociologist Saskia Sassen, produced specifically for this circumstance, in which, amongst other issues, she addressed how materiality is a vehicle for power and invisible forces, and how, currently, the global financial system is capable of incessantly transforming the physical space that surrounds us into commodities.

One point of entry into a complex multifaceted system that has kept gaining power over the last 30 years is high finance – a mode that has nothing to do with traditional banking. Traditional banking, still the most common type of banking across the world, is basically a form of commerce. These, mostly modest banks, sell money, for a price. They could be selling potatoes for a price. Yet with high finance it all changes: it becomes complex, develops endless chains of instruments, all contributing to concentration of wealth at the top. This is radically different from the traditional commercial bank.

A way of opening up that window into a complex world is to focus on the capacity of this type of finance to extract value from even modest operations ... It does so via an admirably complex and effective innovation ... at the heart is the capacity to transform a whole range of basically modest, simple entities, into financial assets. That transformation actually involves some rather complex innovations – basically advanced algorithmic math ...

... it is not easy to understand, but once you do, it is both impressive and horrifying.

High finance is now after actual materialities that it can transform into instruments that are in high demand, such as, for example, asset-backed securities. The difference between high finance and regular commerce when it comes to the material, is that, for regular commerce, the concrete object is the desired object, while for high finance, the material gets transformed into a field of assets, and this serves to produce asset-

backed securities, which is specifically what high level investors want now... they do not want derivatives... as I like to say, those are for the simple people, including me and you.

What we see with our good old eyes: a house, a truck, a bridge, all and more, can today function in two distinct domains: the material domain of the house, the truck, the bridge, and so on, and, in a second domain, that is invisible to our eyes, where via algorithmic mathematics you transform the house, the truck, the bridge etc., into a range of financial instruments that are then far removed from the asset that is based on that house, truck, and bridge... and, being so removed from the original material item, it can now be bought and sold as a financial instrument, many times a day. You are not burdened by, for example, the materiality of the truck, its condition, its size, or what makes it desirable ... it has been neutralized into a financial instrument that you can buy and sell several times.

Land, seen through such perspective is simultaneously two different things. There is land involved in a range of conditions, such as to grow materialities we need, such as food, or to extract oil, metals, etc., but also, in today's financial system, land, as simply land, can feed the making of asset-backed security (detached from the material), which becomes an instrument investors appreciate since derivatives have lost their attraction ...

... land is seen as a desirable asset to construct financial instruments.

Per la mia prima esposizione da Francesca Minini dal titolo *the control of things over subjects is the control of subjects over themselves*, com'è mia abitudine, invece di commissionare un testo a un curatore, ho deciso di provvedere personalmente a scrivere una riflessione per accompagnare le opere, seguita dall'estratto di un'intervista che ho realizzato appositamente per quest'occasione alla professoressa e sociologa Saskia Sassen.

A partire da un atteggiamento che cerca di superare la tradizionale dicotomia tra staticità e azione, la mostra presenta, grazie alla giustapposizione di una serie di elementi e strategie, una critica alla produzione di spazio intesa come riproduzione di forme sociali astratte e di rapporti di forza.

Gli esseri umani costruiscono e trasformano incessantemente lo spazio per soddisfare le proprie necessità e soprattutto per scambiare beni all'interno della società capitalistica di cui sono parte. Questo atteggiamento determina automaticamente la nascita e lo sviluppo di un sistema di limitazioni e di forme di potere e controllo che non sono da intendersi solamente come dominio di una classe sociale sull'altra, ma come dominazione di tutti i soggetti da parte delle strutture sociali astratte che essi stessi costruiscono.

All'interno di questo sistema di limitazioni determinate dall'ubiquità del lavoro e della produzione di valore, siamo condannati a trasformare tutti i pensieri in oggetti. Di conseguenza comprendiamo come la materialità non sia neutrale ma, al contrario, essa diviene l'incarnazione del controllo e della circolazione del potere.

Il potere scorre attraverso le cose e, in molte circostanze, rivela lo scambio di ruoli che avviene tra gli individui e i beni materiali all'interno del capitalismo moderno: la vita diventa oggettificata e sacrificabile, mentre i beni materiali vengono idolatrati e investiti di un valore spirituale.

Oltre allo spazio della galleria, la mostra è composta dai seguenti materiali:
spezzoni di video di ispezioni di pozzi di petrolio, acqua, energia geotermica e per estrazione di gas
frammento di roccia lunare
granulato di rame ottenuto da cavi per la trasmissione di dati ad alta velocità
frammenti di carotaggi recuperati da indagini geotecniche condotte in previsione di lavori di mobilità urbana

l'orologio da polso con funzionamento antiorario di un lavoratore deceduto
folgorite (formazione rocciosa tubolare prodotta dalle scariche dei fulmini nel terreno).

A dispetto dell'idea che le opere d'arte e l'ambiente artistico siano autonomi e carichi di positività, investiti del magico ruolo di poter parlare della decadenza del mondo senza farne effettivamente parte, l'arte è un bene di consumo e, in quanto tale, gioca un ruolo identico a quello delle merci nella riproduzione delle relazioni sociali catastrofiche che ci controllano.

Daniel de Paula

Come nota finale, ecco alcuni brevi frammenti dell'intervista alla sociologa Saskia Sassen.

Attraverso esempi concreti, la professoressa riflette sullo stato attuale della globalizzazione del capitale e sul modo in cui le sue complesse capacità matematiche e tecniche contribuiscono alla produzione di brutalità elementari che agiscono sull'ambiente e, di conseguenza, su innumerevoli popolazioni.

Una struttura poliedrica e complessa che ha continuato a guadagnare potere negli ultimi trent'anni è l'alta finanza, un sistema che non ha nulla a che vedere con le banche tradizionali. Le comuni banche, tutt'ora la modalità di deposito più diffusa in tutto il mondo, sono essenzialmente una sorta di commercio. Questi istituti di credito, per lo più semplici, vendono soldi a un determinato prezzo. Potrebbero anche vendere patate a un prezzo stabilito. Con l'alta finanza invece cambia tutto: il sistema diventa complesso, sviluppa catene ininterrotte di strumenti che contribuiscono a concentrare la ricchezza al vertice. E questo è radicalmente differente dal sistema bancario tradizionale.

Per aprire una finestra su questo mondo complesso possiamo concentrarci sulla capacità di questo tipo di finanza di ottenere un valore dalle operazioni più modeste... Ciò è possibile grazie a un'innovazione incredibilmente complessa ed efficace... al centro c'è la capacità di trasformare un'intera serie di entità sostanzialmente modeste e semplici in attività finanziarie. Questa trasformazione in realtà coinvolge innovazioni abbastanza complesse, essenzialmente algoritmi avanzati...

... non è semplice comprenderlo, ma una volta che ci si riesce, è al contempo impressionante e spaventoso.

Oggi l'alta finanza è interessata agli oggetti materiali che possono essere trasformati in strumenti molto richiesti, come per esempio, gli asset-backed security. La differenza di relazione

che l'alta finanza e il regolare commercio hanno nei confronti della materialità, risiede nel fatto che per il commercio l'oggetto concreto è l'oggetto desiderato, mentre l'alta finanza trasforma l'oggetto in una serie di cespiti per produrre asset-backed security, che è proprio ciò che attualmente gli investitori di alto livello desiderano...non vogliono le derivate che, come mi piace dire, sono per gente semplice, come me e te.

Ciò che vediamo con i nostri occhi: una casa, un autocarro, un ponte, tutto e di più, oggi può appartenere a due domini distinti: quello materiale della casa, dell'autocarro, del ponte e via dicendo, oppure a un altro, invisibile agli occhi dove, attraverso degli algoritmi, la casa, l'autocarro e il ponte si trasformano in una serie di strumenti finanziari che quindi sono ben lontani dal valore insito di quella casa, di quell'autocarro e di quel ponte... ed essendo così distanti dall'oggetto materiale originario, possono essere acquistati e venduti come strumenti finanziari molte volte in un solo giorno. Non esiste, per esempio, il peso della materialità dell'autocarro, delle sue condizioni, delle sue dimensioni e di tutto quello che lo rende desiderabile...è stato neutralizzato in uno strumento finanziario che si può vendere e comprare più volte.

Osservata secondo questa prospettiva, quindi, anche la terra rappresenta allo stesso tempo due cose diverse: esiste la terra coinvolta in una serie di operazioni, come la produzione dei beni che ci servono, come la coltivazione del cibo o l'estrazione di petrolio, metalli ecc...e la terra del sistema finanziario odierno che può alimentare la creazione di asset-backed security che diventano uno strumento che gli investitori apprezzano poiché le derivate hanno perso la loro attrattiva...

...la terra è vista come un bene desiderabile per costruire strumenti finanziari.



the control of things over subjects is the control of subjects over themselves, 2019
Installation view at Francesca Minini, Milan



the control of things over subjects is the control of subjects over themselves, 2019
Installation view at Francesca Minini, Milan



the control of things over subjects is the control of subjects over themselves, 2019
Installation view at Francesca Minini, Milan



the control of things over subjects is the control of subjects over themselves, 2019
Installation view at Francesca Minini, Milan



the control of things over subjects is the control of subjects over themselves, 2019
Installation view at Francesca Minini, Milan



the control of things over subjects is the control of subjects over themselves, 2019
Installation view at Francesca Minini, Milan



the control of things over subjects is the control of subjects over themselves, 2019
Installation view at Francesca Minini, Milan



the control of things over subjects is the control of subjects over themselves, 2019
Installation view at Francesca Minini, Milan



the control of things over subjects is the control of subjects over themselves, 2019
Installation view at Francesca Minini, Milan



the control of things over subjects is the control of subjects over themselves, 2019
Installation view at Francesca Minini, Milan



the control of things over subjects is the control of subjects over themselves, 2019
Installation view at Francesca Minini, Milan



the control of things over subjects is the control of subjects over themselves, 2019
Installation view at Francesca Minini, Milan



the control of things over subjects is the control of subjects over themselves, 2019
Installation view at Francesca Minini, Milan

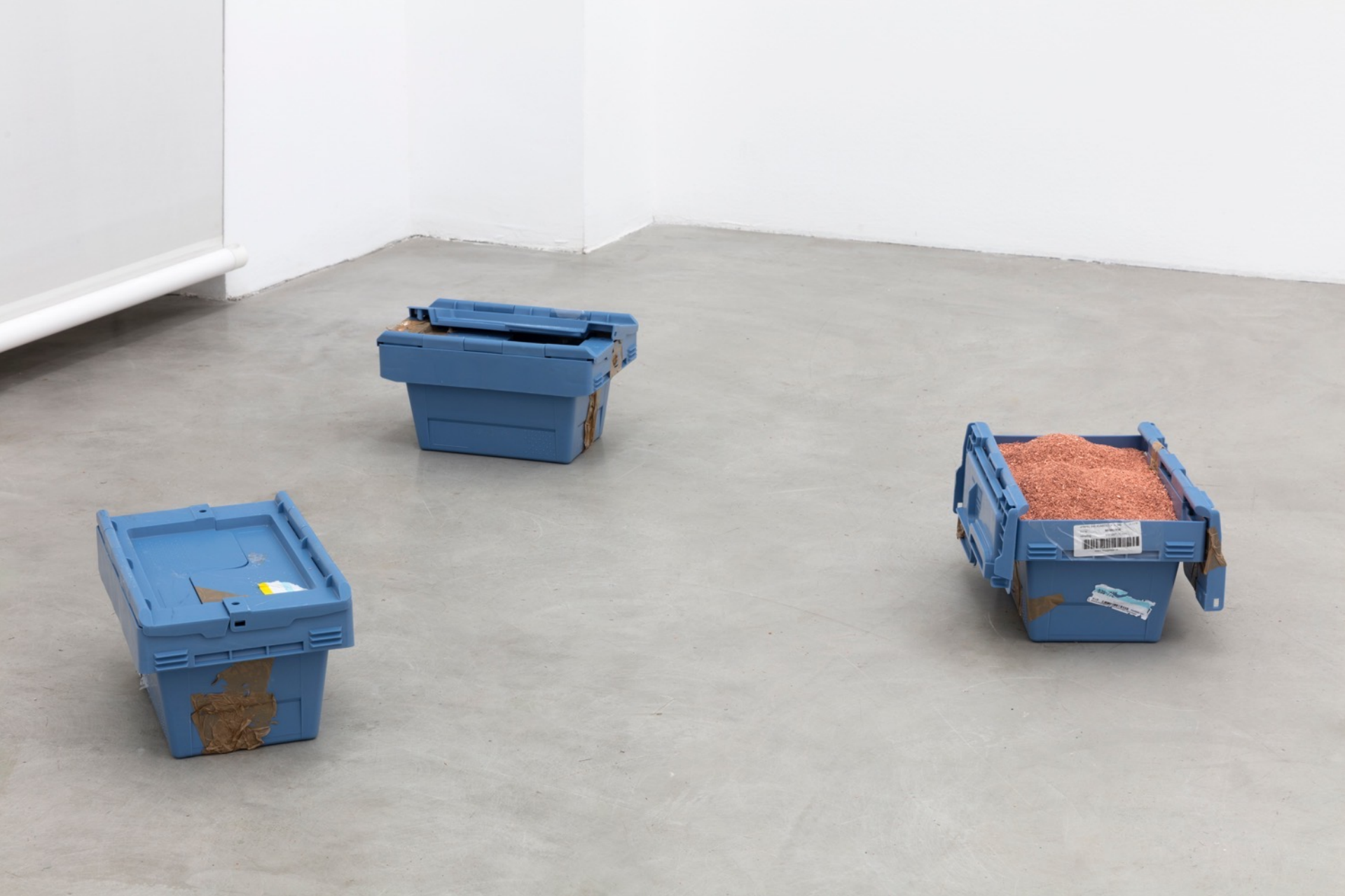

the control of things over subjects is the control of subjects over themselves, 2019
Installation view at Francesca Minini, Milan





the control of things over subjects is the control of subjects over themselves, 2019
Installation view at Francesca Minini, Milan

the control of things over subjects is the control of subjects over themselves, 2019
Installation view at Francesca Minini, Milan



Other shows, artworks and
site specific projects



DANIEL DE PAULA
LULEÅ BIENNIAL:
ON THE THRESHOLD OF 1:1

2024

Lulea



Luleå Biennial: On the threshold of 1:1, 2024
Installation view at Luleå Biennial, Luleå

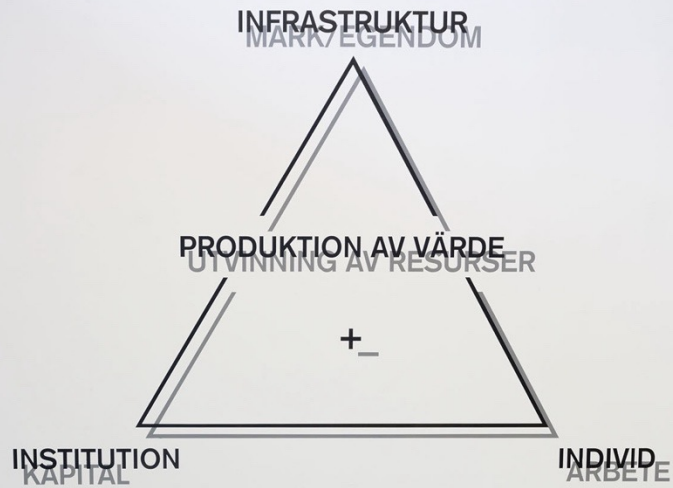

Luleå Biennial: On the threshold of 1:1, 2024
Installation view at Luleå Biennial, Luleå



Luleå Biennial: On the threshold of 1:1, 2024
Installation view at Luleå Biennial, Luleå



DANIEL DE PAULA
XII VIDEO SOUND ART
FESTIVAL *THE LIFE OF
THINGS AND THE
INVISIBLE QUALITIES OF
OBJECT*

2022

Teatro Carcano
Milan

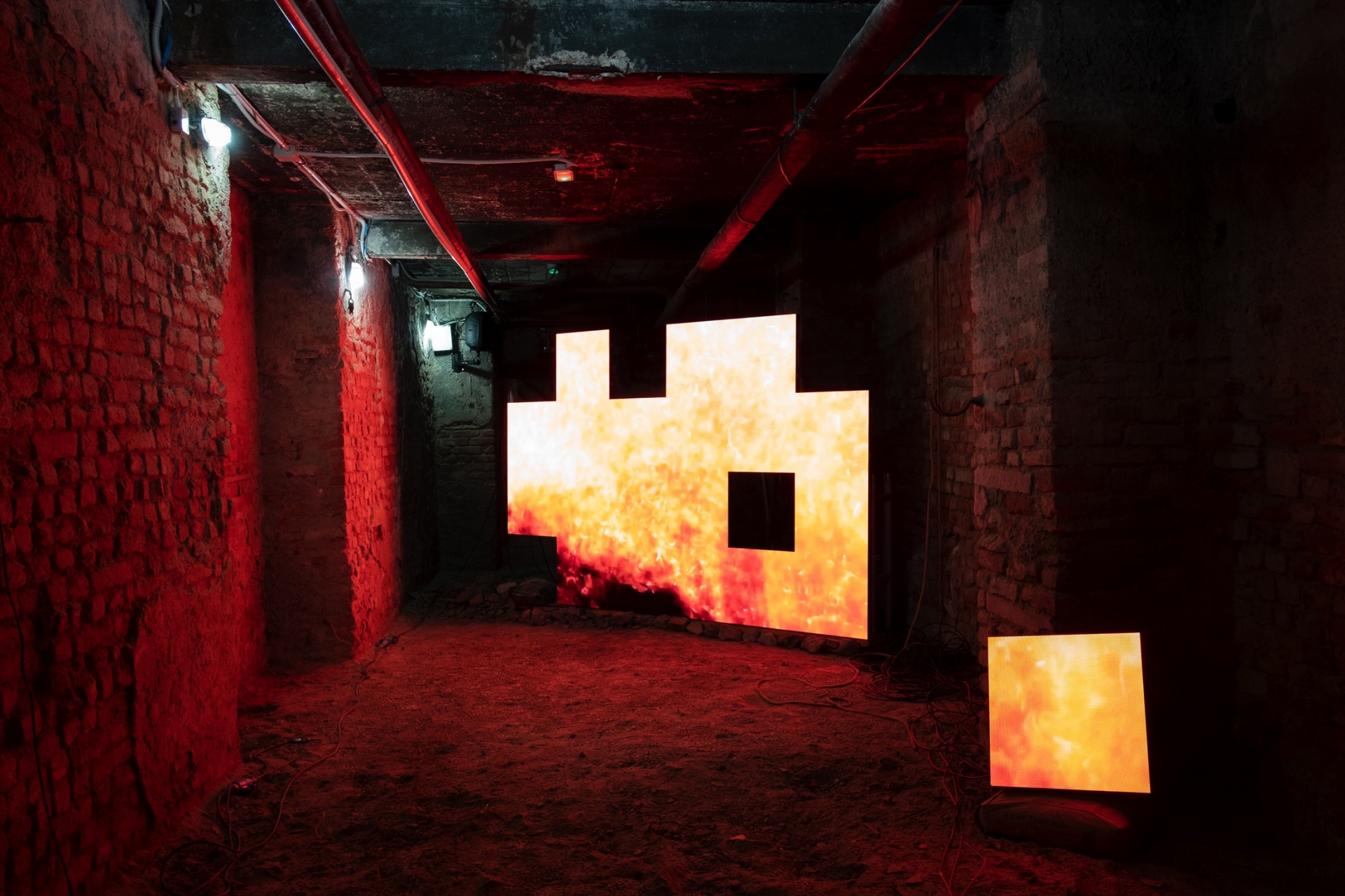

XII Video Sound Art Festival The Life Of Things And The Invisible Qualities Of Object, 2022
Installation view at Teatro Carcano, Milan



XII Video Sound Art Festival The Life Of Things And The Invisible Qualities Of Object, 2022
Installation view at Teatro Carcano, Milan





DANIEL DE PAULA
Manifesto of Fragility

curated by Sam Bardaouil
and Till Fellrath

2022

16th LyonBiennial
Lyon

Daniel de Paula makes works from materials that he borrows or acquires from public and private institutions by means of extensive negotiations. Juxtaposing and decontextualising these various artifacts and images, he interrogates their political, social, economic and historical rationales. For the Lyon Biennale, he has devised a video and sculpture installation in dialogue with Roman funeral mask from Lugdunum - Musée de théâtres romains, which lost its original purpose when reutilized as an architectural and infrastructural element. Daniel de Paula's work seeks to demonstrate that space is a complex network that travels through time, shaping places and relationships.



Manifesto of Fragility, 2022
Installation view at Fondazione Baruchello, Rome



Manifesto of Fragility, 2022
Installation view at Fondazione Baruchello, Rome





DANIEL DE PAULA
Not Quite Nearly Fine

2021

curated by Giulio Squillacciotti

Fondazione Baruchello
Rome



Not Quite Nearly Fine, 2021
Installation view at Fondazione Baruchello, Rome



Not Quite Nearly Fine, 2021
Installation view at Fondazione Baruchello, Rome



DANIEL DE PAULA

Though It's Dark, Still I Sing

2021

curated by Jacopo Crivelli Visconti, Paulo Miyada, Carla Zaccagnini, Francesco Stocchi, Ruth Estévez

34th Bienal de São Paulo



Though It's Dark, Still I Sing, 2021
34th Bienal de São Paulo



Though It's Dark, Still I Sing, 2021
34th Bienal de São Paulo



Though It's Dark, Still I Sing, 2021
34th Bienal de São Paulo



Though It's Dark, Still I Sing, 2021
34th Bienal de São Paulo



Though It's Dark, Still I Sing, 2021
34th Bienal de São Paulo



Though It's Dark, Still I Sing, 2021
34th Bienal de São Paulo



Though It's Dark, Still I Sing, 2021
34th Bienal de São Paulo



Though It's Dark, Still I Sing, 2021
34th Bienal de São Paulo



DANIEL DE PAULA

puro e disposto a salire le stelle

2020

Galleria Massimo Minini,
Brescia



puro e disposto a salire le stelle, 2020
Installation view at Galleria Massimo Minini, Brescia



DANIEL DE PAULA

*And materiality becomes nothing but a mere
representation of a structure of dominance*

2020

Lumen Travo Gallery
Amsterdam



And materiality becomes nothing but a mere representation of a structure of dominance, 20220
Installation view at Lumen Travo Gallery, Amsterdam



Daniel de Paula, 2020
And materiality becomes nothing but a mere representation of a structure of
dominance
Installation view at Lumen Travo Gallery, Amsterdam



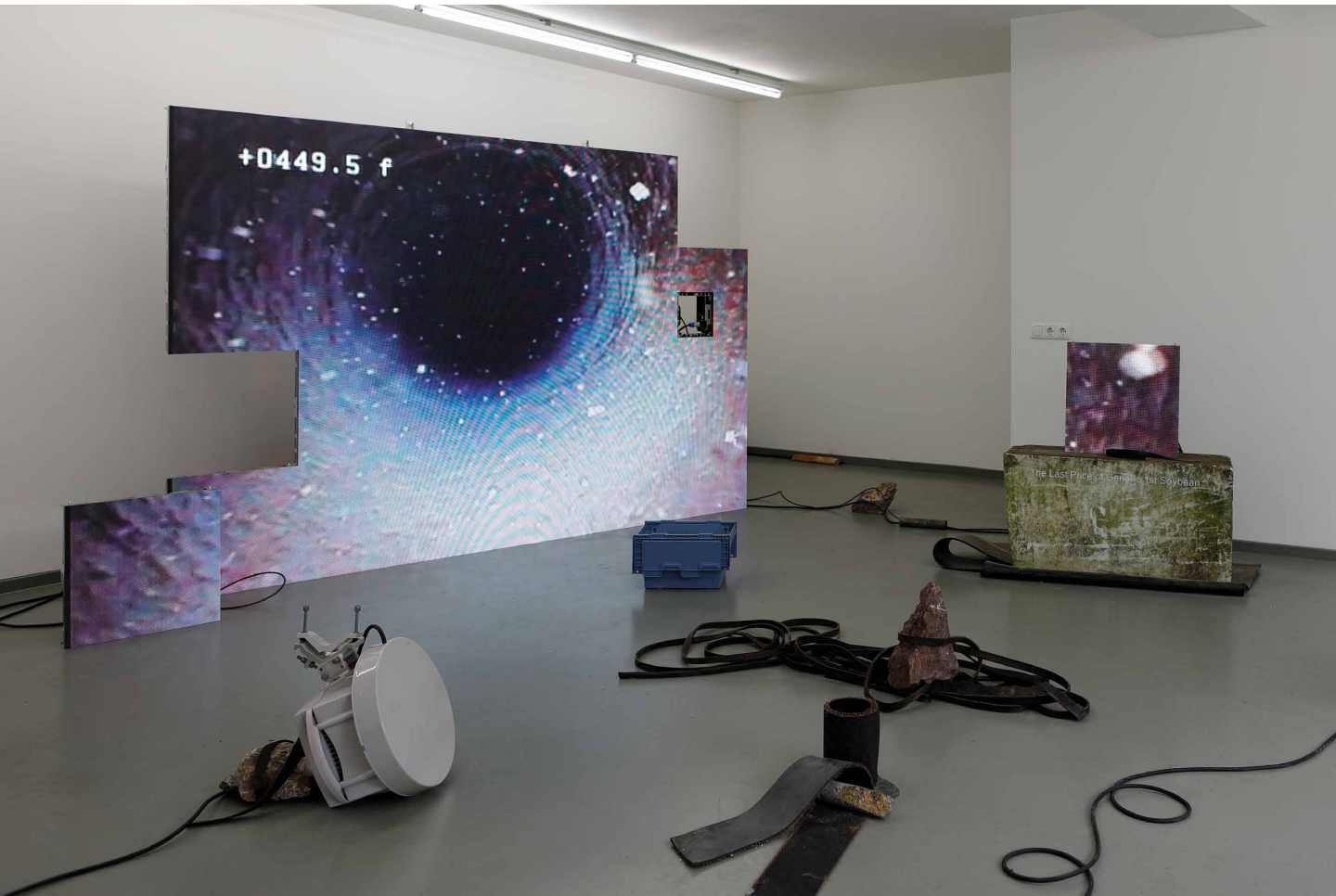

DANIEL DE PAULA
Open Studios

2019

Jan van Eyck Academie
Maastricht



Open Studios, 2019
Installation view at Jan van Eyck Academie, Maastricht



Open Studios, 2019
Installation view at Jan van Eyck Academie, Maastricht





DANIEL DE PAULA

2019

curated by Marina Coelho

Kunsthalle Gent
Gent



Daniel de Paula, 2019
Installation view at Kunsthalle Gent, Gent

Daniel de Paula, 2019
Installation view at Kunsthalle Gent, Gent

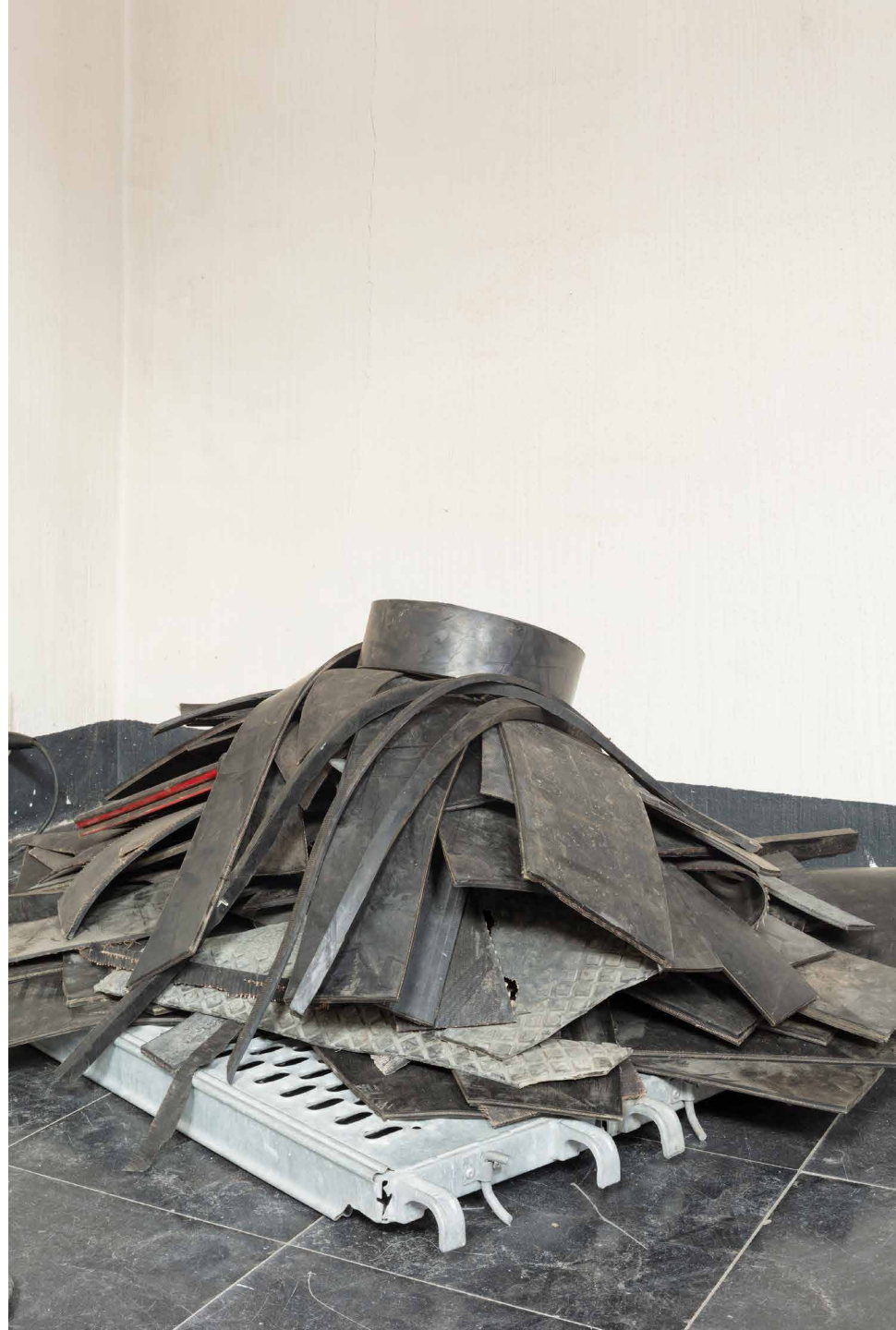



DANIEL DE PAULA
Brasile. Il Coltello nella Carne

2018

curated by Jacopo Crivelli
Visconti

PAC
Milan



Brasile. Il Coltello nella Carne, 2018
Installation view at PAC, Milan

DANIEL DE PAULA
Avenida Paulista

2017

curated by Adriano Pedrosa

MASP
São Paulo





Avenida Paulista, 2017
Installation view at MASP, São Paulo



field of action / field of vision, 2017

installation and negotiation

salvaged street lamps model X-250, used in the public lighting of Avenida Paulista between 1974 and 2011, manufactured by Peterco Iluminação e Eletricidade Ltda. in molded and cast grooved aluminum body with adjustable internal reflectors stamped in aluminum plates, transparent acrylic diffusers and porcelain receptacles [purchased in the context of a public auction of the city after its removal for later exhibition at MASP at Avenida Paulista]

variable dimensions

-

The work field of action / field of vision sheds light on both the historical and current relevance of the Paulista Avenue as an on-going public space and stage of narrative and political dispute, where a variety of oppositional and antagonistic edifices, symbols, protests, marches, events, institutions, and public demonstrations are based and have occurred throughout its over 100-year history. In such sense the salvaged streetlamps and public infrastructure carry the weight of the events that transcribed underneath and through their atmospheric luminous gaze and cloak; from the violent repression of political protests during the military dictatorship in the 1970s and 1980s, to the world's largest annual LGBT pride parade; from conservative and extreme right winged religiously themed marches, to the public uprisings against the raise on public transportation fares; from the unfortunate repeated violent homophobic attacks in which, in some cases the aggressors used fluorescent lamps as weapons, to the Christmas lighting decorations funded by the most profitable banks of the nation, all with headquarters located in the Avenue itself etc.

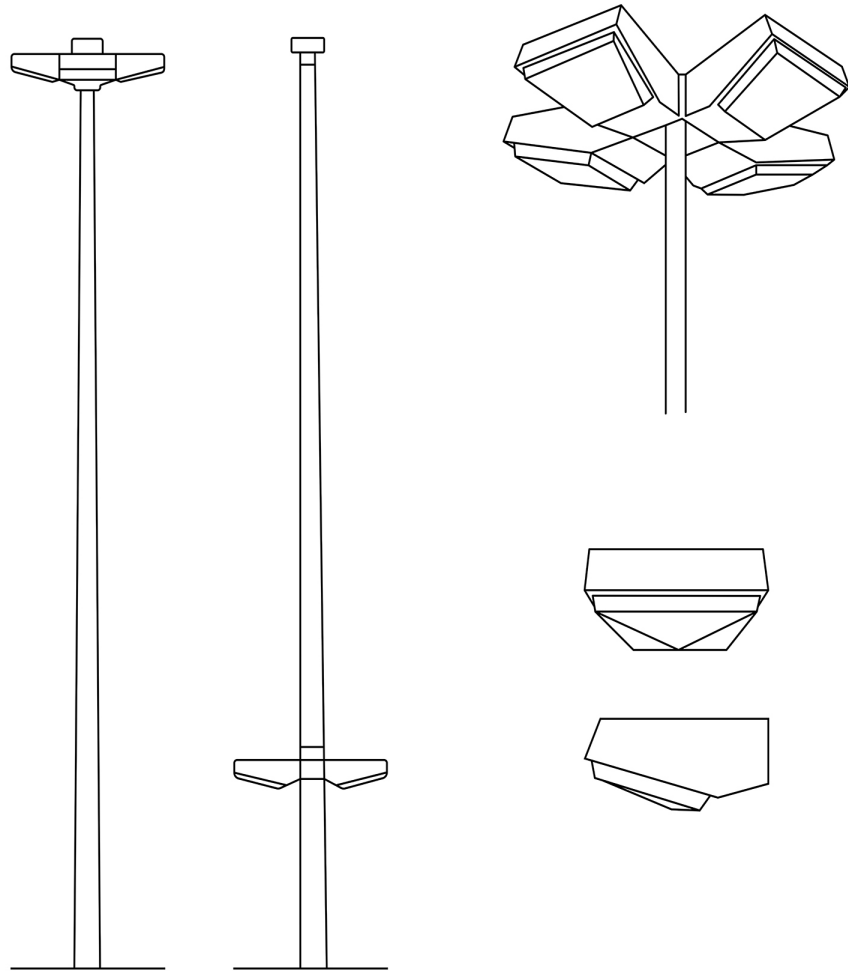

DANIEL DE PAULA
*The Conductive Form Of
Dominant Flows*

2017

Jaqueline Martins Gallery
São Paulo

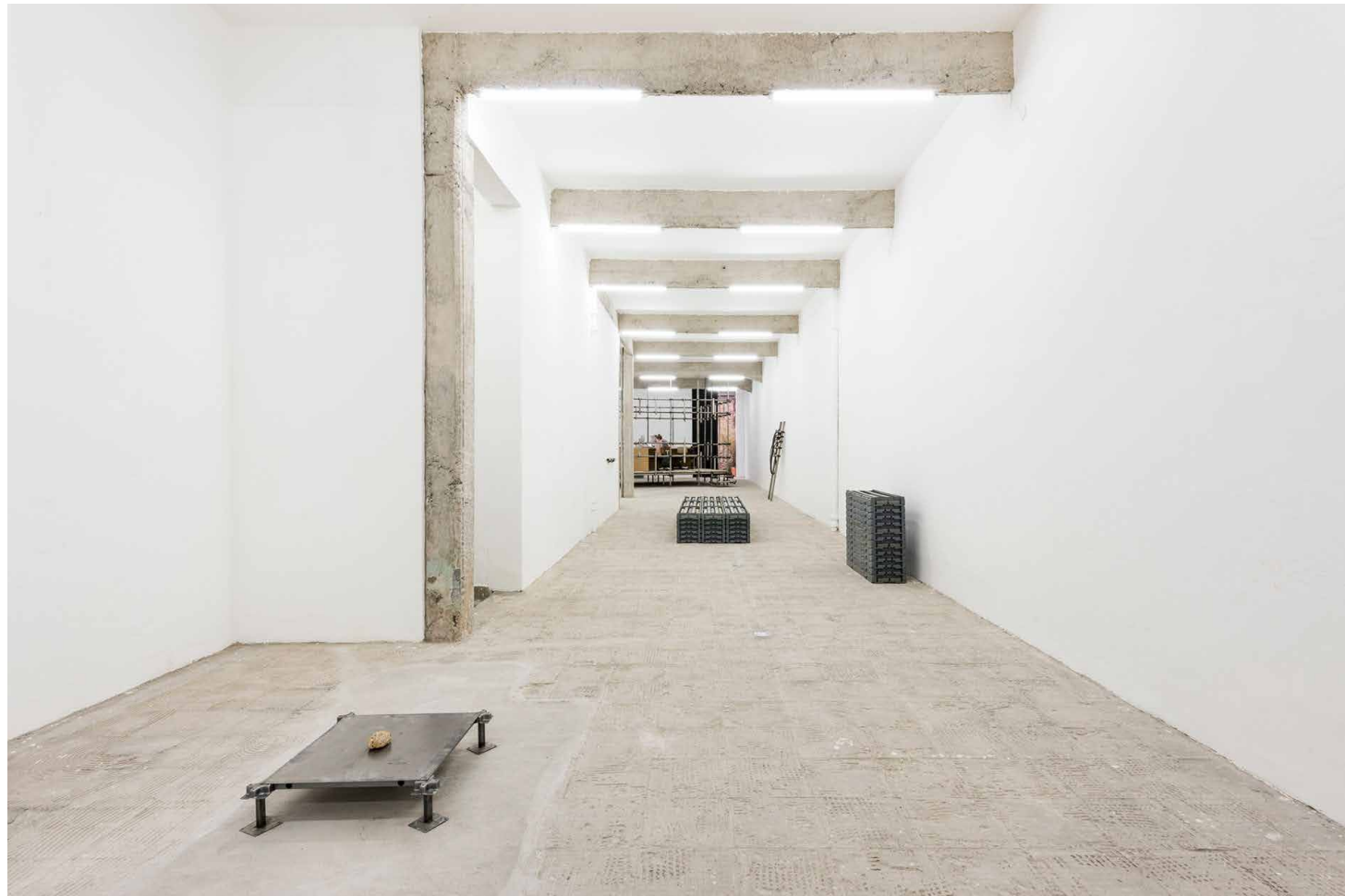



The Conductive Form Of Dominant Flows, 2017
Installation view at Jaqueline Martins Gallery, São Paulo



The Conductive Form Of Dominant Flows, 2017
Installation view at Jaqueline Martins Gallery, São Paulo



DANIEL DE PAULA
Testemunho

2015

curated by Bruno de Almeida

Galeria Leme
São Paulo



Testemunho, 2015
Installation view at Galeria Leme, São Paulo

**geologic time scale
superimposed to the plan of the gallery and installation**

**Works of transport infrastructure
construction companies and their consortiums**

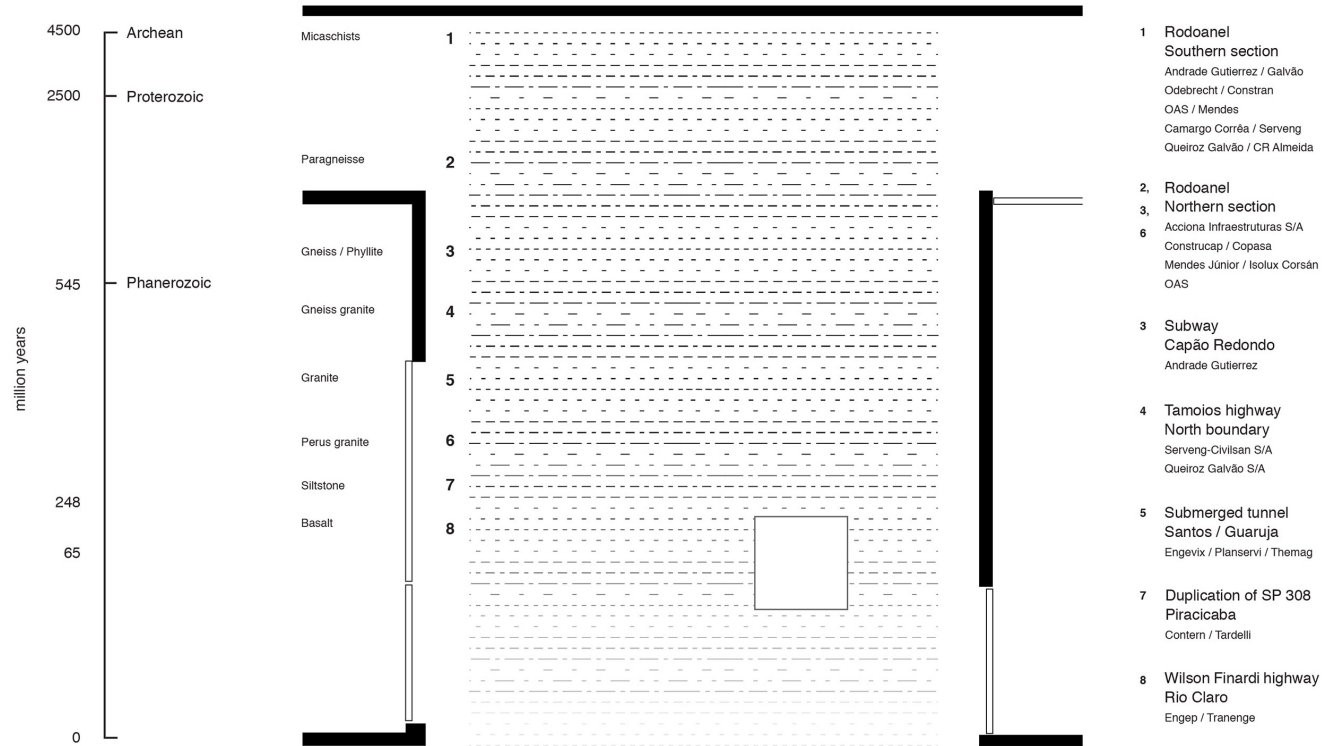

testemunho, 2015

installation and negotiation
core samples resulting from geotechnical surveys, performed for overpriced public
works of urban mobility in the state of São Paulo (such as the subway, highways,
bridges, tunnels, among others)

approximately 1 linear km of core samples ordered chronologically according to their
geological age confined to the courtyard of Galeria Leme

(other presentations of the work have taken place, always in close relation to the
spatial and contextual particularities of exhibition space and its surroundings)

The work also points, indexes, and proclaims physical and material evidence towards
and against recent corruption scandals that have taken place in Brazil for several
decades, in which São Paulo's state government is directly tied to, fostering the
growth of the construction companies based in its state. Moreover the state is known
as being the largest claimant of public works in the country, surpassing, in some
moments, claims and infrastructural works of the entire union. Furthermore the
state government is proud and vocal about being able to gather and host virtually all
macro-contractors in the heavy constructions and infrastructure segment in the
nation, including main known actors such as the companies Andrade Gutierrez,
Mendes Júnior, Odebrecht, Camargo Corrêa, OAS, among others. This relationship
between the state and large construction corporations has been carefully
constructed in order to enable the creation of favorable conditions and agreements
for
structuring and maintaining a solid market for the sector, reproducing favorable
conditions for the continuation of a dominating political and corporate strata.

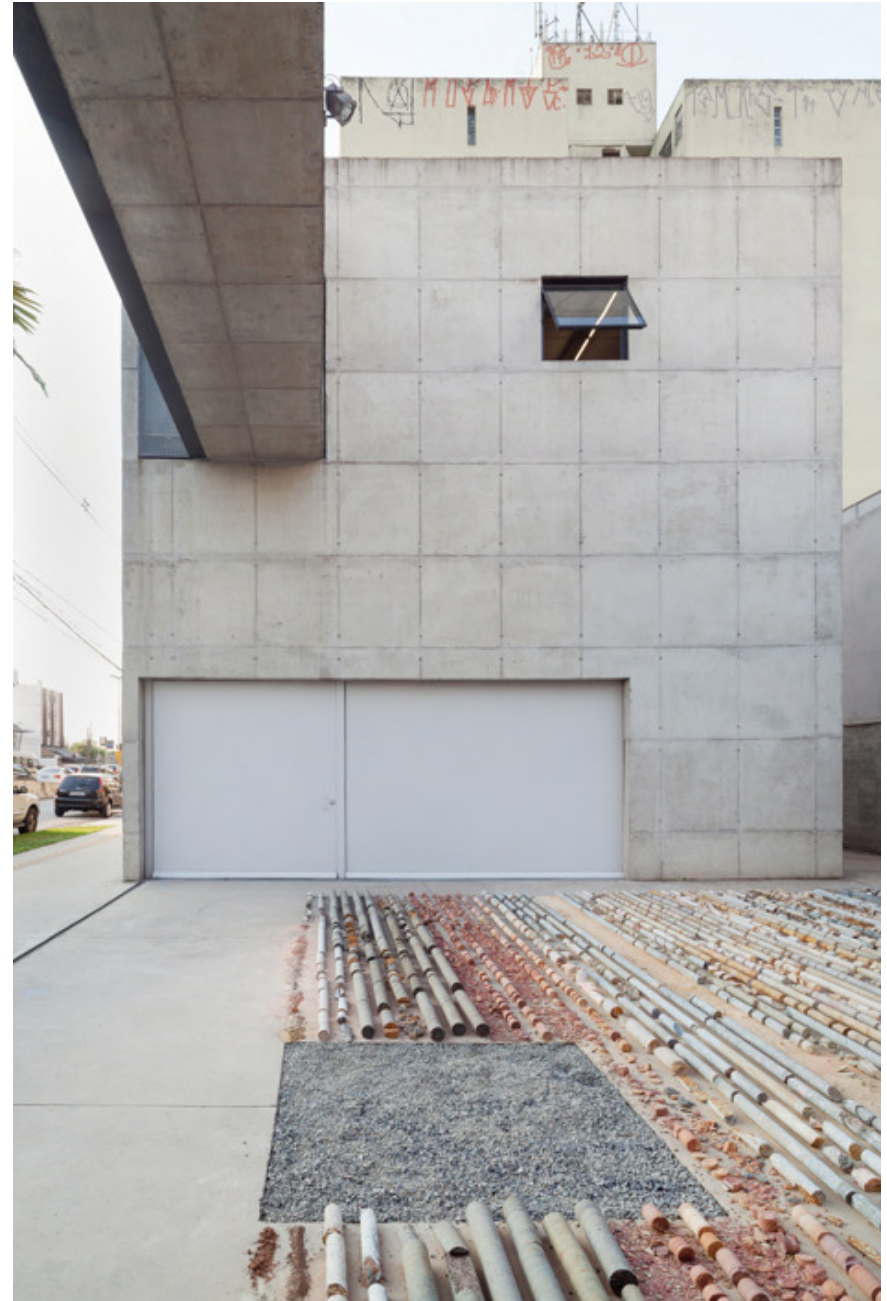



DANIEL DE PAULA
Objects Of Mobility,
Actions Of Permanence

2014

White Cube Gallery
São Paulo



DANIEL DE PAULA
Open Cube

2013

curated by Adriano Pedrosa

White Cube Gallery
Mason's Yard
London

Open Cube, 2013
Installation view at White Cube Gallery Mason's Yard, London

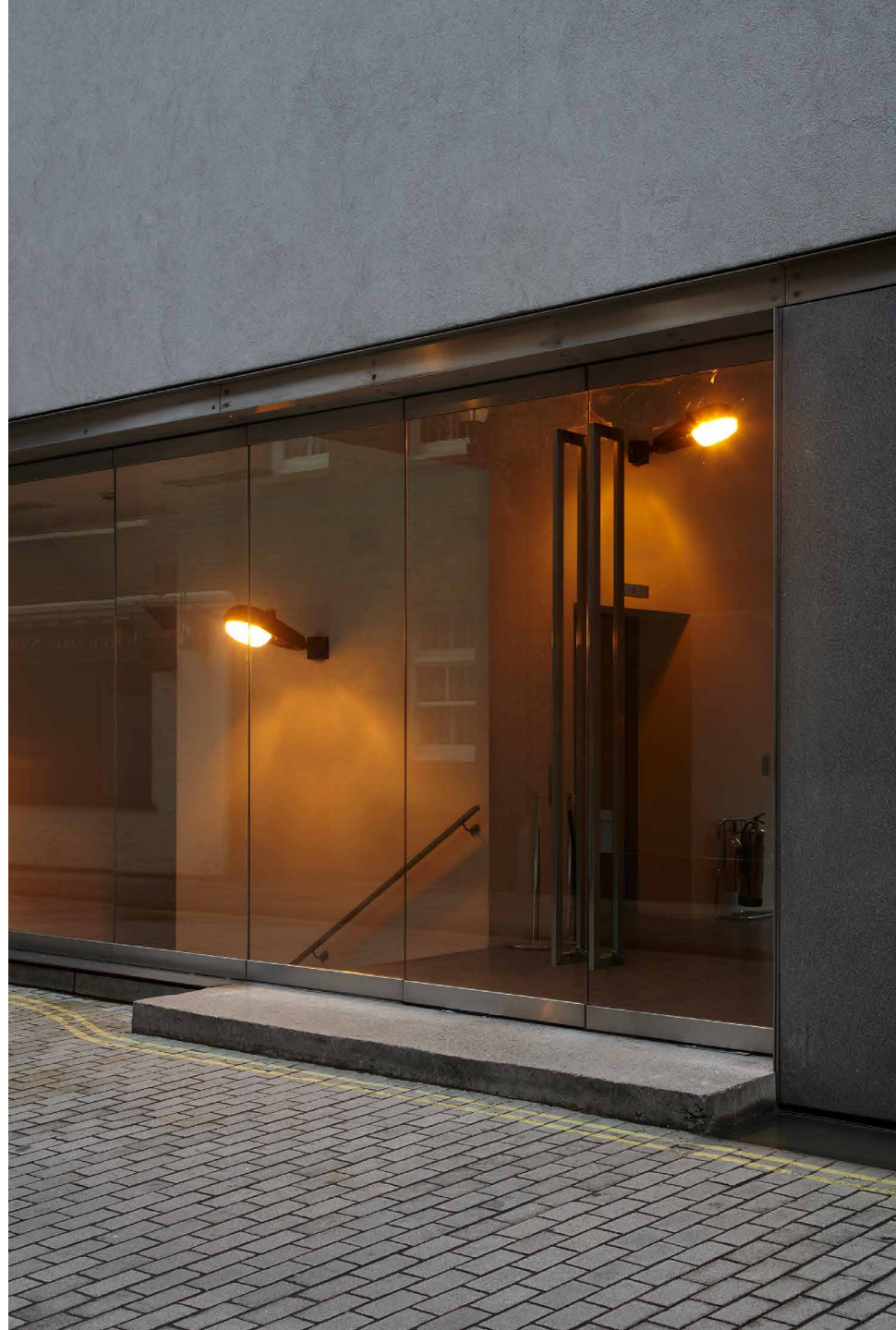

DANIEL DE PAULA

b. Boston, USA 1987

Lives and works between São Paulo (BR) and Maastricht (NL)

EDUCATION

2017

Masters in Human Geography, USP, University of São Paulo, (interrupted), São Paulo (BR)

2015

Public School of Astrophysics, "Meteorites, Meteors, and Meteoroids", São Paulo (BR)

2014

School of São Paulo, "PIESP – Program of the School of São Paulo" – coordinated (BR)

by Adriano Pedrosa and Anna Paula Cohen, São Paulo (BR)

2012

FAAP – Fundação Armando Alvares Penteado, BFA in Visual Arts, São Paulo (BR)

ARTISTIC RESIDENCIES

2019

De Fabriek, Eindhoven (NL)

Foundation BAD, Rotterdam (NL)

2018-19

Jan Van Eyck Academie, Maastricht (NL)

2016

FLACC, Genk (BE)

2014

Kiosko, Santa Cruz de la Sierra (BO)

2014

Red Bull Station, São Paulo (BR)

2013

Cité Internationale des Arts, Paris (FR)

2012

Casa Tomada, São Paulo (BR)

AWARDS AND DISTINCTIONS

2016

ArtNexus SP-arte, São Paulo (BR)

2015

ProAC – State Government Exhibition Award, São Paulo (BR)

2011

Acquisition Award, CCSP - Centro Cultural São Paulo, São Paulo (BR)

2011

2nd Prize, Instituto Tomie Ohtake, São Paulo (BR)

SOLO EXHIBITIONS

2023

INFRASTRUCTURE, INSTITUTION; INDIVIDUAL, infrastructure,, Galeria Jaqueline Martins, São Paulo (BR)

INALIENABLE, IMPRESCRIPTIBLE E INEMBARGABLE, Labor, Mexico City (MX)

2020

REPOSE (with Marissa Lee Benedict - David Rueter), Arts Club of Chicago, Chicago (US)

AND MATERIALITY BECOMES NOTHING BUT A MERE REPRESENTATION OF A STRUCTURE OF DOMINANCE, Lumen Travo Gallery, Amsterdam (NL)

2019

THE CONTROL OF THINGS OVER SUBJECTS IS THE CONTROL OF SUBJECTS OVER THEMSELVES, Francesca Minini, Milan (IT)

1:1, curated by Bruno de Almeida, Jaqueline Martins Gallery, São Paulo (BR)

OPEN STUDIOS, Jan van Eyck Academie, Maastricht (NL)

Kunsthalle Ghent, Curated by Marina Coelho, Ghent (BE)

COMPOSITION, De Aanschouw, Rotterdam (NL)

ESTRUCTURA INSUPERÁVEL, Kunsthal Gent, Ghent (BE)

2017

THE CONDUCTIVE FORM OF DOMINANT FLOWS, Jaqueline Martins Gallery, São Paulo (BR)

2016

GRAVIDADE, Edital ProAC, Cratera de Colônia, São Paulo (BR)

OPEN PLAN, SP-arte, Pavilhão da Bienal, São Paulo (BR)

FLACC, Genk (BE)

2015

TESTEMUNHO, curated by Bruno de Almeida, Galeria Leme, São Paulo (BR)

2014

OBJECTS OF MOBILITY, ACTIONS OF PERMANENCE, White Cube Gallery, São Paulo (BR)

2013

TO EXTEND A CORRIDOR, Cité Internationale des Arts, Paris (FR)

2011

PROGRAM OF EXHIBITIONS, CCSP - Centro Cultural São Paulo, São Paulo (BR)

SELECTED GROUP EXHIBITIONS

2024

ON THE THRESHOLD OF 1:1, Luleåbiennalen, Luleå (SW)

2023

TRACES OF A CATHODE, with Paulo Arraiano, Diogo da Cruz, Olga Grotova, Gwenu Llwyd, David Rickard, S1 Artspace, Sheffield, (UK)

2022

VIDEO SOUND ART FESTIVAL, THE LIFE OF THINGS AND THE INVISIBLE QUALITIES OF OBJECTS, Teatro Carcano, Milan (IT)

16th LYON BIENNALE OF CONTEMPORARY ART: MANIFESTO OF FRAGILITY, curated by Sam Bardaouil and Till Fellrath, Lyon Biennial, Lyon (FR)

2021

THOUGH IT'S DARK, STILL I SING, curated by Jacopo Crivelli Visconti, Paulo Miyada, Carla Zaccagnini, Francesco Stocchi, Ruth Estévez

34th Bienal de São Paulo, São Paulo (BR)

NOT QUITE NEARLY FINE, curated by Giulio Squillacciotti, Fondazione Baruchello, Rome (IT)

2020

PURO E DISPOSTO A SALIRE LE STELLE, Galleria Massimo Minini, Brescia (IT)

2019

COMEÇO DE SÉCULO, curated by Germano Dushá and with ass. curator Guilherme Teixeira, Jaqueline Martins Gallery, São Paulo (BR)

UNTITLED, with Renata de Bonis, De Aanschouw, Rotterdam (NL)
ESCRITURAS CONTAGIADAS POR ATACAMA, curated by Rodolfo Andaur, NoAutomático, Monterrey (MX)
PARALLAX, curated by Artun Alaska, Wilfried Lentz Gallery, Rotterdam (NL)

2018

BRAZIL, KNIFE IN THE FLESH, curated by Jacopo Crivelli Visconti, PAC, Milan (IT)
MATRIX OF ACTUAL TIME, curated by Jacopo Crivelli Visconti, MAC, São Paulo (BR)

2017

AVENIDA PAULISTA, curated by Adriano Pedrosa, MASP, São Paulo (BR)
METROPOLIS: THE SÃO PAULO EXPERIENCE, curated by Tadeu Chiarelli, Estação Pinacoteca, São Paulo (BR)
WE HAVE THE WEIGHTS, WE HAVE THE MEASURES, Copperfield Gallery, London (UK)
UN PIANO NA SELVA Selva, Periscópio Arte Contemporânea, Belo Horizonte (BR)

2016

LIBERAÇÃO E CONSUMO, curated by Mirtes Marins de Oliveira, Instituto Figueiredo Ferraz, Ribeirão Preto (BR)
OPEN PLAN, curated by Jacopo Crivelli Visconti, SP-arte, São Paulo (BR)
ESFORÇO-DESEMPENHO, curated by Germano Dushá, Galeria Athena Contemporânea, Rio de Janeiro (BR)

2015

NÓS ENTRE OS EXTREMOS, curated by Paulo Miyada, Instituto Tomie Ohtake, São Paulo (BR)
PERMANÊNCIAS & DESTRUIÇÕES, curated by João Paulo Quintella, Oi Futuro, Rio de Janeiro (BR)
XYZ, Galeria Pilar, São Paulo (BR)
VORAGEM DE HISTÓRIA, Observatório, São Paulo (BR)
FALSO MOVIMENTO, Galeria Luciana Caravello, Rio de Janeiro (BR)
CHOPE ABUBUYA, Centro de La Cultura Plurinacional, Santa Cruz de la Sierra (BO)

2014

LA PARTE QUE NO TE PERTENECE, curated by Paulo Miyada, Galeria Maisterravalbuena, Madrid (ES)
ONSITE TAP, short-listed by Mike Nelson, Temporary Arts Project, London (UK)
ABUBUYA KM 0, curated by Rodolfo Andaur, Casa de la Cultura de Trinidad, Trinidad (BO)
APARIÇÃO, Galeria Athena Contemporânea, Rio de Janeiro (BR)
MADE BY...FEITO POR BRASILEIROS, Hospital Matarazzo, São Paulo (BR)

2013

OPEN CUBE, curated by Adriano Pedrosa, White Cube Gallery Mason's Yard, London (UK)
45TH ARTS ANNUAL, invited artist, FAAP, São Paulo (BR)
ESPAÇOS INDEPENDENTES – A ALMA É O SEGREDO DO NEGÓCIO, Galerias Funarte de Artes Visuais, São Paulo, BR
EQUIVOCÁBULOS, Edifício Lutetia FAAP, São Paulo (BR)

2012

DA PRÓXIMA VEZ EU FAZIA TUDO DIFERENTE, curated by Diego Matos, Pivô, São Paulo (BR)
PROCESSOS PÚBLICOS, Paço das Artes, São Paulo (BR)
DOCUMENTAÇÃO – PROCESSOS PÚBLICOS, Museu da Cultura PUC, São Paulo (BR)

2011

PROJETO IMÓVEL, Edifício Copan, São Paulo (BR)
O DESVIO É O ALVO, curated by Fernando Oliva and Luisa Duarte, Entretanto, São Paulo (BR)
I.O.T.E., UNESP, São Paulo (BR)

2010

EDP ENERGIAS DA ARTE, curated by Agnaldo Farias, Instituto Tomie Ohtake, São Paulo (BR)
EXPERIÊNCIA HÉLIO OITICICA, Itaú Cultural, São Paulo (BR)